



**CONNECTRIC**  
SYSTEMS INC.

28-207 Edgeley Blvd., Concord, Ontario, L4K 4B5  
Ph: 905-669-0080 Fax: 905-669-0082  
www.connectric.com info@connectric.com

**motrona**<sup>®</sup>  
safety - control - motion - interface



## touchMATRIX<sup>®</sup> Indicator IX350 / IX355

SSI indicator for absolute encoders, with touchscreen and graphic display

### Product features:

- Master or Slave operation with clock frequencies up to 1 MHz
- For single turn and multi turn encoders with SSI formats from 10 ... 32 Bit
- Bright and high-contrast display with event-dependent color variations
- Emulation of a 7-segment display inclusively icons and units
- Intuitive and easy parameterization by plain text and touchscreen
- 5 V / 24 V auxiliary output for encoder supply
- Linearization with 24 control points
- Numerous features, e. g. scaling, bit blanking etc.
- 3.78 x 1.89 inch norm panel housing and IP65 protection

### Available options:

**IX350:** Basic unit with SSI interface, 3 control inputs, 24 VDC encoder supply

**IX355:** Basic unit like IX350, with open-circuit monitoring, 5 / 24 VDC encoder supply

- Option **AC:** Power supply 115 / 230 VAC
- Option **AO:** 16 bit analog output, 4 control outputs, serial RS232 interface
- Option **AR:** 16 bit analog output, 4 control outputs, serial RS485 interface
- Option **CO:** 4 control outputs, serial RS232 interface
- Option **CR:** 4 control outputs, serial RS485 interface
- Option **RL:** 2 relay outputs

Options can be combined

<b>Version:</b>	<b>Description:</b>
IX350_01a_oi/cn/Jun-17	First Version
IX350_01b_oi/cn/Jul-17	First Revision
IX350_01c_oi/cn/Jul-17	Revision
IX350_02a_oi/cn/Nov-17	Expansion of the scale units
IX350_02b_oi/cn/Apr-18	Revision
IX350_02b_oi/cn/April-18	Expansion of the serial interface

**Legal notices:**

All contents included in this manual are protected by the terms of use and copyrights of motrona GmbH. Any reproduction, modification, usage or publication in other electronic and printed media as well as in the internet requires prior written authorization by motrona GmbH.

# Table of content

<b>1. Safety Instructions and Responsibility</b>	<b>4</b>
1.1. General Safety Instructions	4
1.2. Use according to the intended purpose	4
1.3. Installation	5
1.4. Cleaning, Maintenance and Service Notes	5
<b>2. Introduction</b>	<b>6</b>
2.1. Operation mode	6
2.2. Function diagram	6
<b>3. Electrical Connections</b>	<b>7</b>
3.1. DC Power Supply	7
3.2. Auxiliary Voltage Output	7
3.3. SSI-Inputs	8
3.4. Control Inputs	10
3.5. Analog Output (Option AO/AR)	10
3.6. Serial interface (Option AO/AR/CO/CR)	11
3.7. Control-Output (Option AO/AR/CO/CR)	11
3.8. AC Power supply (Option AC)	12
3.9. Relay-Output (Option RL)	12
<b>4. Display and touch screen</b>	<b>13</b>
4.1. Screen structure for parametrization	13
4.2. Screen structure in operation	14
4.3. Error Message	15
<b>5. Parameter / Overview-Menu Structure</b>	<b>16</b>
5.1. General Menu	18
5.2. SSI Properties	21
5.3. Preselection Values	24
5.4. Preselection 1 Menu	25
5.5. Preselection 2 Menu	28
5.6. Preselection 3 Menu	29
5.7. Preselection 4 Menu	30
5.8. Serial Menu	31
5.9. Analog Menu	33
5.10. Command Menu	34
5.11. Display Menu	36
5.12. Linearization Menu	37
<b>6. Appendix</b>	<b>38</b>
6.1. Data readout via serial interface	38
6.2. Parameter / serial codes	39
6.3. Linearization	43
6.4. Reading SSI-Value	45
6.5. Internal processing and calculation of SSI data	46
6.6. Dimensions	48
6.7. Technical Specifications:	49

# 1. Safety Instructions and Responsibility

## 1.1. General Safety Instructions

This operation manual is a significant component of the unit and includes important rules and hints about the installation, function and usage. Non-observance can result in damage and/or impairment of the functions to the unit or the machine or even in injury to persons using the equipment!

**Please read the following instructions carefully before operating the device and observe all safety and warning instructions! Keep the manual for later use.**

A pertinent qualification of the respective staff is a fundamental requirement in order to use these manual. The unit must be installed, connected and put into operation by a qualified electrician.

**Liability exclusion:** The manufacturer is not liable for personal injury and/or damage to property and for consequential damage, due to incorrect handling, installation and operation. Further claims, due to errors in the operation manual as well as misinterpretations are excluded from liability.

In addition the manufacturer reserves the right to modify the hardware, software or operation manual at any time and without prior notice. Therefore, there might be minor differences between the unit and the descriptions in operation manual.

The raiser respectively positioner is exclusively responsible for the safety of the system and equipment where the unit will be integrated.

During installation or maintenance all general and also all country- and application-specific safety rules and standards must be observed.

If the device is used in processes, where a failure or faulty operation could damage the system or injure persons, appropriate precautions to avoid such consequences must be taken.

## 1.2. Use according to the intended purpose

The unit is intended exclusively for use in industrial machines, constructions and systems. Non-conforming usage does not correspond to the provisions and lies within the sole responsibility of the user. The manufacturer is not liable for damages which have arisen through unsuitable and improper use.

Please note that device may only be installed in proper form and used in a technically perfect condition (in accordance to the Technical Specifications). The device is not suitable for operation in explosion-proof areas or areas which are excluded by the EN 61010-1 standard.

## 1.3. Installation

The device is only allowed to be installed and operated within the permissible temperature range. Please ensure an adequate ventilation and avoid all direct contact between the device and hot or aggressive gases and liquids.

Before installation or maintenance, the unit must be disconnected from all voltage-sources. Further it must be ensured that no danger can arise by touching the disconnected voltage-sources.

Devices which are supplied by AC-voltages must be connected exclusively by switches, respectively circuit-breakers with the low voltage network. The switch or circuit-breaker must be placed as near as possible to the device and further indicated as separator.

Incoming as well as outgoing wires and wires for extra low voltages (ELV) must be separated from dangerous electrical cables (SELV circuits) by using a double resp. increased isolation.

All selected wires and isolations must conform to the provided voltage- and temperature-ranges. Further all country- and application-specific standards, which are relevant for structure, form and quality of the wires, must be ensured. Indications about the permissible wire cross-sections for wiring are described in the Technical Specifications.

Before first start-up it must be ensured that all connections and wires are firmly seated and secured in the screw terminals. All (inclusively unused) terminals must be fastened by turning the relevant screws clockwise up to the stop.

Overvoltage at the connections must be limited to values in accordance to the overvoltage category II.

**For placement, wiring, environmental conditions as well as shielding and earthing/grounding of the supply lines the general standards of industrial automation industry and the specific shielding instructions of the manufacturer are valid.** Please find all respective hints and rules on [www.motrona.com/download.html](http://www.motrona.com/download.html) --> "[General EMC Rules for Wiring, Screening and Earthing]" .

## 1.4. Cleaning, Maintenance and Service Notes

To clean the front of the unit please use only a slightly damp (not wet!), soft cloth. For the rear no cleaning is necessary. For an unscheduled, individual cleaning of the rear the maintenance staff or assembler is self-responsible.

During normal operation no maintenance is necessary. In case of unexpected problems, failures or malfunctions the device must be shipped for back to the manufacturer for checking, adjustment and reparation (if necessary). Unauthorized opening and repairing can have negative effects or failures to the protection-measures of the unit.

## 2. Introduction

The SSI display device is designed for panel mounting. It is universally applicable, with its intuitive operation, the extensive features and options.

### 2.1. Operation mode

All functions are can be configured in the parameter menu.

The device can be set to one of the following operation modes:

- MASTER
  - -The clock for the connected sensor is produced
  - -The both clock terminals (CLK, / CLK) are configured as outputs in this case
- SLAVE
  - -The clock for the encoder is generated by an external device (the SSI master).
  - -The both clock terminals (CLK, / CLK) are configured as inputs in this case

### 2.2. Function diagram

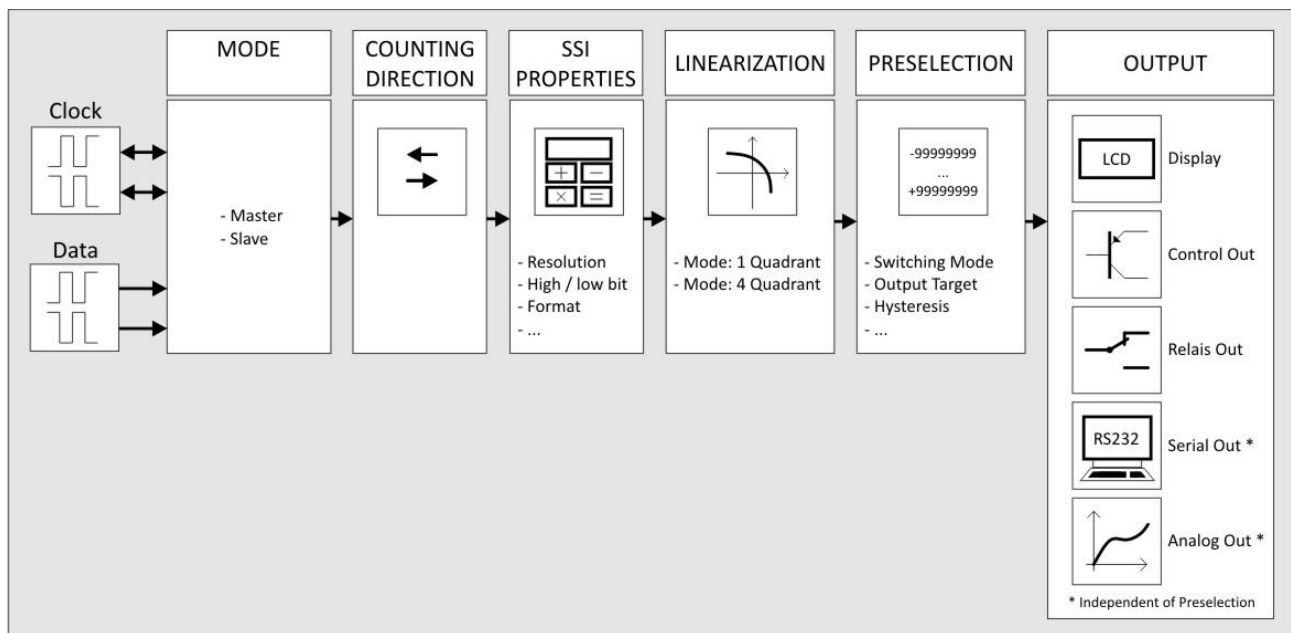

### 3. Electrical Connections

The terminal screws should be tightened with a slotted screwdriver (blade width 2mm).

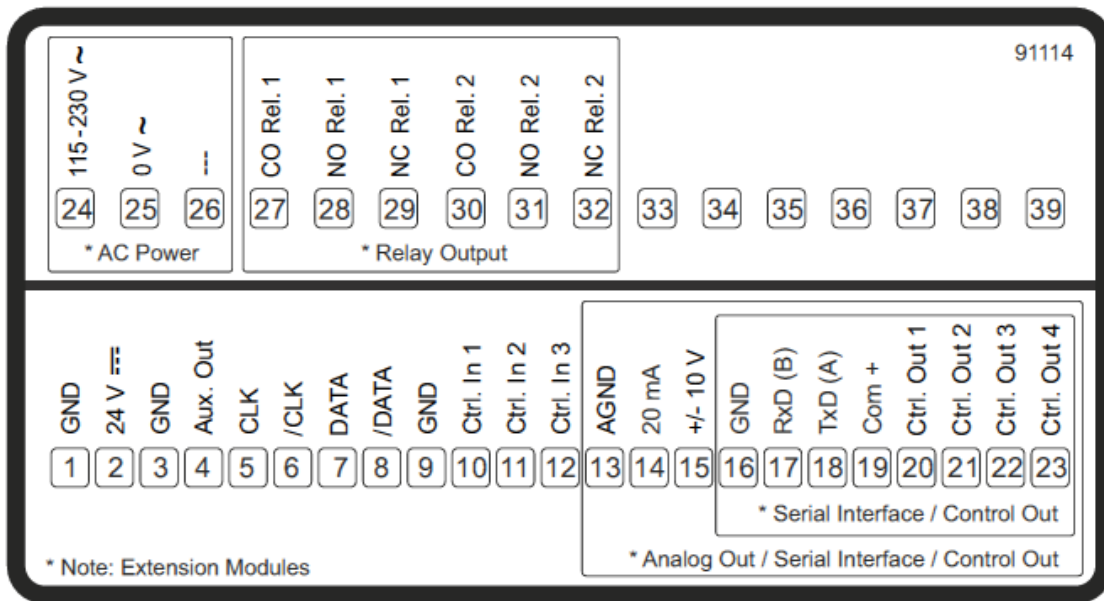

#### 3.1. DC Power Supply

The unit accepts DC supply from 18 to 30 V at the terminals 1 and 2. The power consumption depends on the level of the supply voltage with approx. 100 mA and the additional current required at the Auxiliary Voltage Output.

All GND terminals are internally interconnected.

#### 3.2. Auxiliary Voltage Output

Terminal 3 and 4 provide an auxiliary output for supply of sensors and encoders. The output voltage depends on the power supply.

DC version	AC version
The encoder voltage is approx. 1 V lower than the power supply voltage at terminal 1 and 2 and should be loaded with max. 250 mA.	The encoder voltage is 24 VDC ( $\pm 15\%$ ) and should be loaded with max. 150 mA up to 45 degrees Celsius. At higher temperature the maximum output current is reduced to 80 mA.

At IX355 devices, the auxiliary voltages output is switchable from 24 VDC to 5 VDC.

### 3.3. SSI-Inputs

At Terminal 5, 6, 7 and 8, the connection is available for SSI signals. The basic settings must be set in the menu SSI PROPERTIES.

Wiring for **MODE Master**:

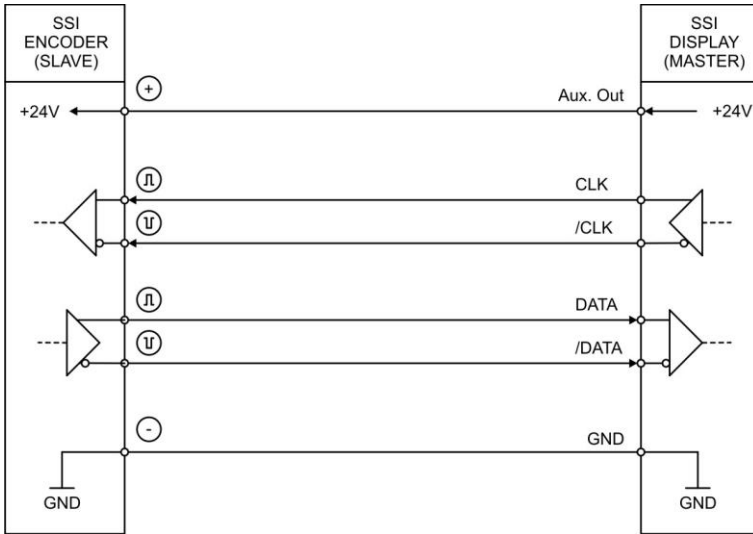

Wiring for **MODE Slave**:

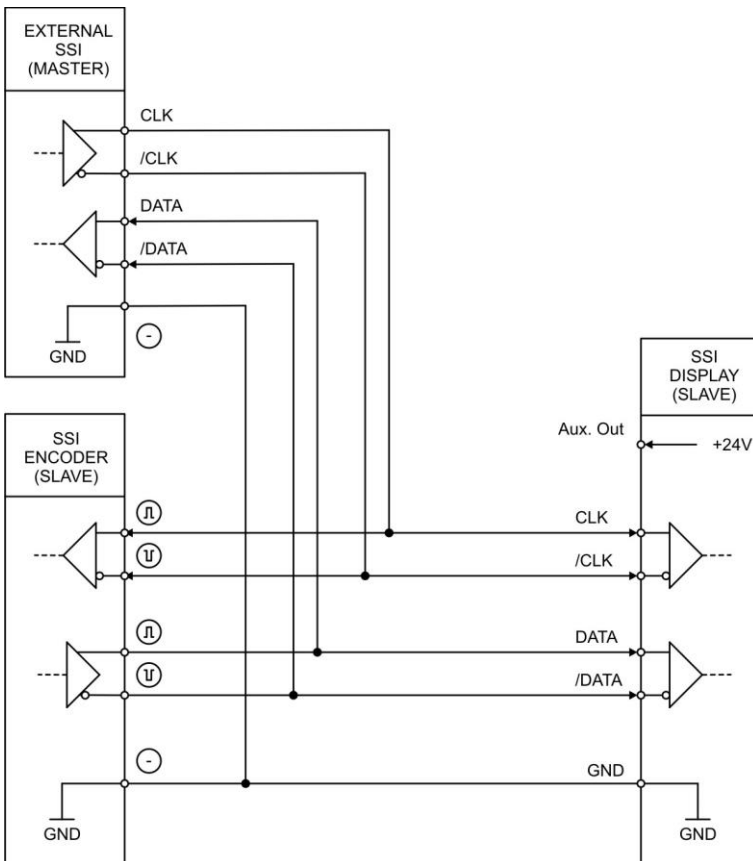



## Continuation „SSI-Inputs“:

The IX355 includes an open-circuit monitoring (only with termination, e.g. 120 ohm). In slave MODE, CLK, /CLK and DATA, /DATA are monitored. In master MODE, only DATA, /DATA are monitored.

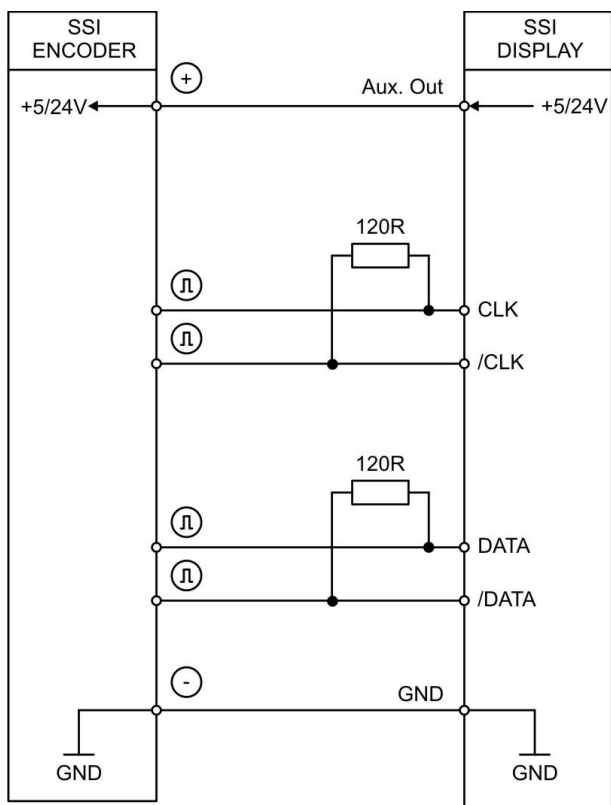

## Error detection

/DATA	DATA	/CLK	CLK	Status
+	+	+	+	Stable data
+	+	+	-	Stable data (not guaranteed), no error detection
+	+	-	+	Stable data (not guaranteed), no error detection
+	+	-	-	Display value freezes, no error detection
+	-	+	+	Error
+	-	+	-	Error
+	-	-	+	Error
+	-	-	-	Error
-	+	+	+	Error
-	+	+	-	Error
-	+	-	+	Error
-	+	-	-	Error
-	-	+	+	Error
-	-	+	-	Error
-	-	-	+	Error
-	-	-	-	Error

If the encoder supply (GND or UB+) is demolished, an error is detected (regardless of CLK,/CLK, data,/DATA).

### 3.4 Control Inputs

The three control inputs at terminal 10, 11 and 12 have HTL PNP characteristics.

In the COMMAND MENU the programmable functions for the control inputs can be assigned.

Available functions are: reset the display value, display switching, locking the touch screen or release the lock function of the control or relay outputs.

Wiring of the control inputs:

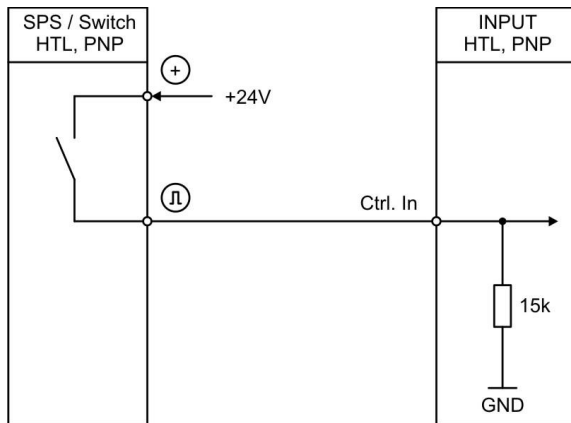

Unconnected PNP inputs are always “LOW” and unconnected NPN inputs are always “HIGH”. All inputs are designed to receive impulses from electrical impulse sources.

#### Notice for mechanical switching contacts:

When exceptionally mechanical contacts are used, please connect an external capacitor between GND (-) and the corresponding input (+). A capacity of 10  $\mu$ F will reduce the input frequency to 20 Hz and miscounting due to contact bouncing will be eliminated.

### 3.4. Analog Output (Option AO/AR)

A 16 bit analog output is available at terminal 13 and 14 / 15

This output can be configured and scaled in the ANALOG MENU.

The following configuration is possible:

- Voltage output: -10 ... +10 V
- Current output: 0 ... 20 mA
- Current output: 4 ... 20 mA

The analog output is proportional to the display value and is referenced to potential AGND. AGND and GND are internally interconnected.



**Important:**

A parallel operation with voltage and current output at the analog output is not allowed.

### 3.5. Serial interface (Option AO/AR/CO/CR)

A serial interface (RS232 or RS485) is available at terminal 16, 17 und 18. This interface can be configured in the SERIAL MENU.

The serial interface RS232 or RS485 can be used:

- for easy setup and commissioning of the units
- to modify settings and parameters during operation
- to read out internal states and actual measuring values by PC or PLC

The following drawing shows the connection to a PC by using a standard Sub-D-9 connector:

Connection of the RS232 interface:

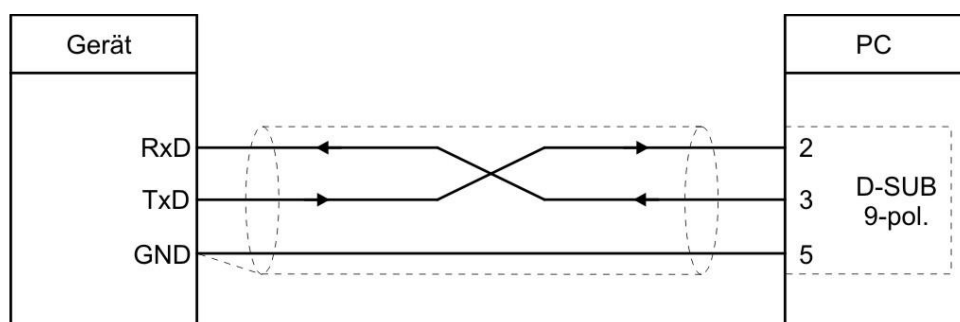

Connection of the RS485 interface:

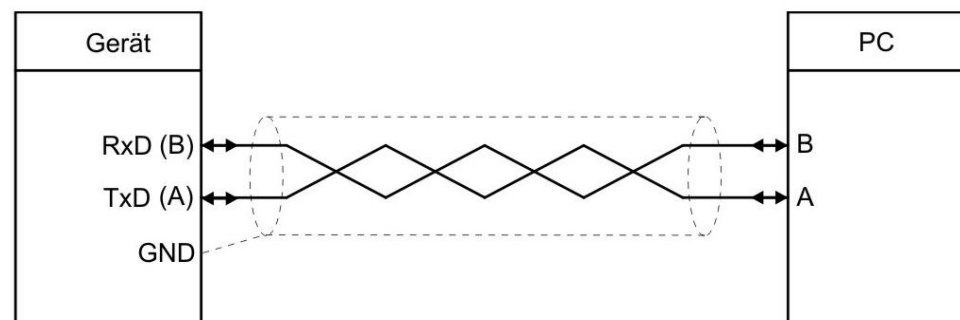

### 3.6. Control-Output (Option AO/AR/CO/CR)

Four control outputs are available at terminal 20, 21, 22 and 23.

Switching conditions can be set in the PRESELECTION MENU. The output Ctrl. Out1 – 4 are fast PNP outputs with a switching capability of 5 – 30 Volt / 200 mA per channel. The switching states is displayed (display with unit and status bar) as C1 ... C4.

The switching voltage of the outputs must be applied to input terminal 19 (COM+).

In case of switching inductive loads it is advisable to use external filtering of the coils.

Wiring of the control-outputs:

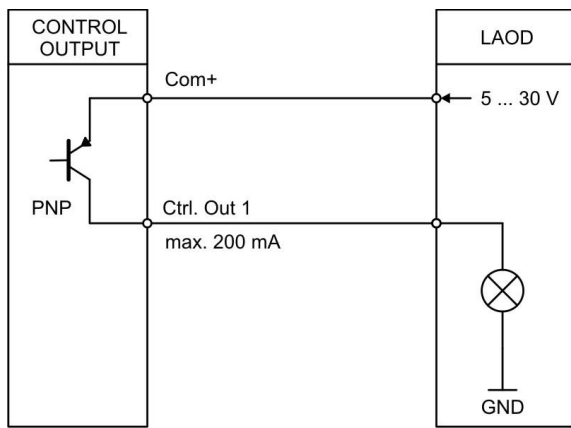

### 3.7. AC Power supply (Option AC)

The unit accepts AC supply from 115 to 230 V at the terminals 24 and 25. The power consumption depends on the level of the supply voltage with approx. 3VA and the additional current required at the auxiliary voltage output.

Devices with option AC can also be supplied with a DC voltage between 18 and 30 VDC via Terminals 1 and 2.

### 3.8. Relay-Output (Option RL)

Two relay outputs with potential-free changeover contacts are available at terminal 27, 28, 28, 30, 31 and 32. Switching conditions can be set in the PRESELECTION MENU. The switching states are displayed (display with unit and status bar) as K1 and K4.

AC-switching capacity max 250 VAC/ max 3 A / 750 VA

DC-switching capacity max 150 VAC/ max 2 A / 50 W

Wiring of the relay outputs

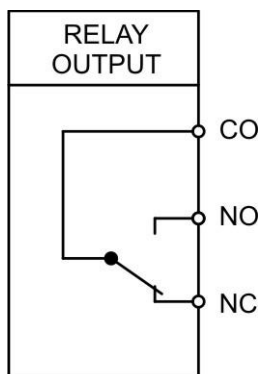

## 4. Display and touch screen

### 4.1. Screen structure for parametrization

The parameter menus and the parameters are described in chapter 5.



#### Start setup procedure:

To edit the parameters, press the touchscreen for 3 seconds.



#### Menu selection:

Select the parameter menu via arrow buttons and confirm with "OK".

The menu selection can be terminated with „C“.



#### Parameter selection:

Select the parameter via arrow buttons and confirm with „OK“.

The parameter selection can be terminated with „C“.



#### Parameter editing:

Edit the parameter via arrow button up and down, shift cursor via left and right and save with „OK“.

The parameter editing can be terminated with „C“.



Parameter changes becomes active only after closing the menu selection.

## 4.2. Screen structure in operation

The following displays are available during operation. Depending on the device version and the selected operating mode, only certain representations are displayed.



### Display with unit and status bar

To switch to the next display, press the touch screen.

Control - or Relay status are only shown with Option AO, CO, RL.



### Display single and multi-turn value:

Display value for diagnostic purposes - raw data, no influence on/by device functions.

To switch to the next display, press the top of the screen.



### Display with command keys

To switch to the next display, press the top of the screen.



### Display for quick start for enter preselection values (PRESELECT VALUES)

To switch to the next display, press the top of the screen or the "skip" button.

This is only possible with Option AO, CO, RL



### Display with minimum and maximum value

To switch to the next display, press the top of the screen or the "skip" button.

### 4.3. Error Message

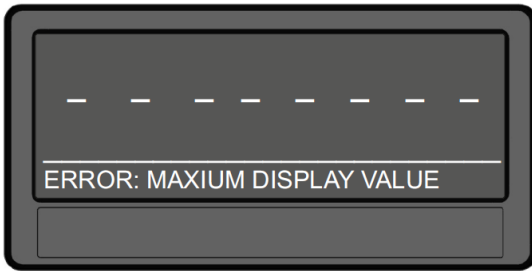

#### ERROR: MAXIMUM DISPLAY VALUE

Display value is greater than + 99,999,999

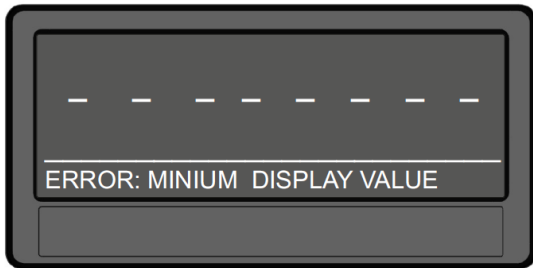

#### ERROR: MINIMUM DISPLAY VALUE

Display value is less than -99,999,999

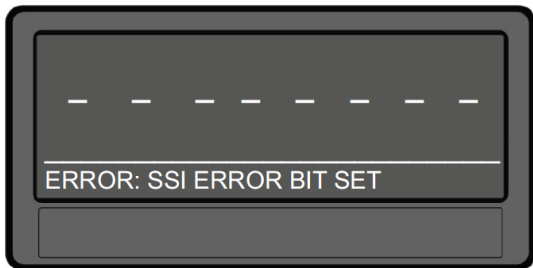

#### ERROR: SSI ERROR BIT SET

The error bit of the SSI encoder is set.

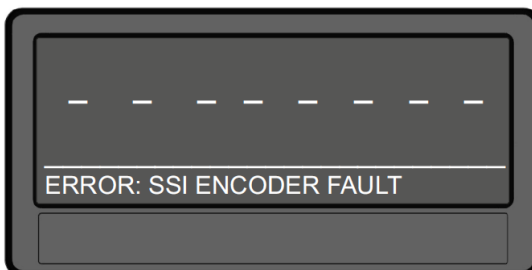

#### ERROR: SSI ENCODER FAULT

Encoder error (e.g. open-circuit) only at IX355



In case of error, the measurement result is set to 0.  
With option A0, the analogue output is controlled with 0 V or 0 mA and with option C0 and A0 the limit value monitoring is performed with the reference value "0".

## 5. Parameter / Overview-Menu Structure

This section provides an overview of the menus and their parameters. The menu names are printed bold and the associated parameters are listed under the menu name. Depending on the device version and the selected operation mode, only the necessary menus / parameters are shown.

<b>Menu / Parameter</b>
<b>GENERAL MENU</b>
DISPLAY FORMAT
FACTOR
DIVIDER
ADDITIVE VALUE
DECIMAL POINT
SCALE UNITS
LINEARIZATION MODE
PIN PRESELECTION
PIN PARAMETER
FACTORY SETTINGS

<b>Menu / Parameter</b>
<b>SSI PROPERTIES</b>
MODE
ENCODER RESOLUTION
BIT PER REVOLUTION
DATA FORMAT
BAUD RATE
HIGHT BIT
LOW BIT
SSI OFFSET
DIRECTION
ROUND LOOP VALUE
SAMPLING TIME
ERROR BIT
ERROR POLARITY
ENCODER SUPPLY



Menu / Parameter
<b>PRESELECTION VALUES</b>
PRESELECTION 1 PRESELECTION 2 PRESELECTION 3 PRESELECTION 4
<b>PRESELECTION 1 MENU</b>
MODE 1 HYSTERESIS 1 PULSE TIME 1 OUTPUT TARGET 1 OUTPUT POLARITY 1 OUTPUT LOCK 1 START UP DELAY 1 EVENT COLOR 1
<b>PRESELECTION 2 MENU</b>
MODE 2 HYSTERESIS 2 PULSE TIME 2 OUTPUT TARGET 2 OUTPUT POLARITY 2 OUTPUT LOCK 2 START UP DELAY 2 EVENT COLOR 2
<b>PRESELECTION 3 MENU</b>
MODE 3 HYSTERESIS 3 PULSE TIME 3 OUTPUT TARGET 3 OUTPUT POLARITY 3 OUTPUT LOCK 3 START UP DELAY 3 EVENT COLOR 3
<b>PRESELECTION 4 MENU</b>
MODE 4 HYSTERESIS 4 PULSE TIME 4 OUTPUT TARGET 4 OUTPUT POLARITY 4 OUTPUT LOCK 4 START UP DELAY 4 EVENT COLOR 4

Menu / Parameter
<b>SERIAL MENU</b>
UNIT NUMBER SERIAL BAUD RATE SERIAL FORMAT SERIAL INIT SERIAL PROTOCOL SERIAL TIMER SERIAL VALUE
<b>ANALOG MENU</b>
ANALOG FORMAT ANALOG START ANALOG END ANALOG GAIN ANALOG OFFSET
<b>COMMAND MENU</b>
INPUT 1 ACTION INPUT 1 CONFIG INPUT 2 ACTION INPUT 2 CONFIG INPUT 3 ACTION INPUT 3 CONFIG
<b>DISPLAY MENU</b>
COLOR BRIGHTNESS CONTRAST SCREEN SAVER UP-DATE-TIME FONT
<b>LINEARISATION MENU</b>
P1(X) P1(Y) P2(X) P2(Y) ... ... P23(X) P23(Y) P24(X) P24(Y)

## 5.1. General Menu

### DISPLAY FORMAT

This parameter selects the Display Format. The corresponding decimal point will be set automatically by display format 999999:59 or 9999:59:59.

0	99999999	Without format customization
1	999999:59	Display angle minutes / seconds
2	9999:59:59	Display in angle minutes : seconds

### FACTOR

This parameter defines the factor.

-99999999	Smallest value
1	Default value
99999999	Highest value

### DIVIDER

This parameter defines the divider.

-99999999	Smallest value
1	Default value
99999999	Highest value

### ADDITIVE VALUE

This parameter defines the additive constant.

-99999999	Smallest value
0	Default value
99999999	Highest value

### DECIMAL POINT

This value defines the position of the decimal point.

0	NO	No decimal point
1	000000.0	Decimal point at the specified position
2	000000.00	Decimal point at the specified position
3	00000.000	Decimal point at the specified position
4	0000.0000	Decimal point at the specified position
5	000.00000	Decimal point at the specified position
6	00.000000	Decimal point at the specified position
7	0.0000000	Decimal point at the specified position

Continuation „General Menu“:

**SCALE UNITS**

This parameter defines the required engineering unit. This parameter does not affect the calculation of the display value. The number of decimal places must be defined with the parameter DECIMAL POINT.

0	inch	Default																																																																																																
1	feet																																																																																																	
2	mm																																																																																																	
3	cm																																																																																																	
4	m																																																																																																	
5	Stueck																																																																																																	
6	pcs																																																																																																	
7	Grad																																																																																																	
8	degree																																																																																																	
9	Min:Sec																																																																																																	
10	G:M:S																																																																																																	
11	%																																																																																																	
12	mbar																																																																																																	
13	bar																																																																																																	
14	psi																																																																																																	
15	Pa																																																																																																	
16	kPa																																																																																																	
17	g																																																																																																	
18	kg																																																																																																	
19	t																																																																																																	
20	lb																																																																																																	
21	oz																																																																																																	
22	ml																																																																																																	
23	l																																																																																																	
24	cm <sup>3</sup>																																																																																																	
25	m <sup>3</sup>																																																																																																	
26	gal																																																																																																	
27	Edit Unit	<p>A customized unit with up to 16 digits can be edited using this parameter. Pressing the "OK" button opens the Edit Unit Menu. A unit can be created using the arrow keys. (pressing and holding the arrow keys the characters scroll fast). The "OK" button saves the Edit Unit Menu. The "C" button closes the Edit Unit Menu.</p> <table border="1"> <tr> <td></td> <td>!</td> <td>"</td> <td>#</td> <td>\$</td> <td>%</td> <td>&amp;</td> <td>'</td> <td>(</td> <td>)</td> <td>*</td> <td>+</td> <td>,</td> <td>-</td> <td>.</td> <td>/</td> </tr> <tr> <td>0</td> <td>1</td> <td>2</td> <td>3</td> <td>4</td> <td>5</td> <td>6</td> <td>7</td> <td>8</td> <td>9</td> <td>:</td> <td>;</td> <td>&lt;</td> <td>=</td> <td>&gt;</td> <td>?</td> </tr> <tr> <td>@</td> <td>A</td> <td>B</td> <td>C</td> <td>D</td> <td>E</td> <td>F</td> <td>G</td> <td>H</td> <td>I</td> <td>J</td> <td>K</td> <td>L</td> <td>M</td> <td>N</td> <td>O</td> </tr> <tr> <td>P</td> <td>Q</td> <td>R</td> <td>S</td> <td>T</td> <td>U</td> <td>V</td> <td>W</td> <td>X</td> <td>Y</td> <td>Z</td> <td>[</td> <td>\</td> <td>]</td> <td>^</td> <td>_</td> </tr> <tr> <td>`</td> <td>a</td> <td>b</td> <td>c</td> <td>d</td> <td>e</td> <td>f</td> <td>g</td> <td>h</td> <td>i</td> <td>j</td> <td>k</td> <td>l</td> <td>m</td> <td>n</td> <td>o</td> </tr> <tr> <td>p</td> <td>q</td> <td>r</td> <td>s</td> <td>t</td> <td>u</td> <td>v</td> <td>w</td> <td>x</td> <td>y</td> <td>z</td> <td>{</td> <td> </td> <td>}</td> <td>~</td> <td></td> </tr> </table>		!	"	#	\$	%	&	'	(	)	*	+	,	-	.	/	0	1	2	3	4	5	6	7	8	9	:	;	<	=	>	?	@	A	B	C	D	E	F	G	H	I	J	K	L	M	N	O	P	Q	R	S	T	U	V	W	X	Y	Z	[	\	]	^	_	`	a	b	c	d	e	f	g	h	i	j	k	l	m	n	o	p	q	r	s	t	u	v	w	x	y	z	{		}	~	
	!	"	#	\$	%	&	'	(	)	*	+	,	-	.	/																																																																																			
0	1	2	3	4	5	6	7	8	9	:	;	<	=	>	?																																																																																			
@	A	B	C	D	E	F	G	H	I	J	K	L	M	N	O																																																																																			
P	Q	R	S	T	U	V	W	X	Y	Z	[	\	]	^	_																																																																																			
`	a	b	c	d	e	f	g	h	i	j	k	l	m	n	o																																																																																			
p	q	r	s	t	u	v	w	x	y	z	{		}	~																																																																																				

Continuation „General Menu“:

<b>LINEARIZATION MODE</b>		
This parameter defines the linearization function. See chapter 6.1.		
0	<b>OFF</b>	No linearization
1	<b>1 QUADRANT</b>	Linearization in the 1. quadrant
2	<b>4 QUADRANT</b>	Linearization in all 4 quadrants

<b>PIN PRESELECTION</b>		
This parameter defines the PIN-code to lock the quick start of the menu PRESELECTION VALUE for entering the preselection values. (Master PIN 6079).		
This Lock function is only useful in conjunction with active lock function in PIN PARAMETER.		
	<b>0000</b>	No lock
	...	
	<b>9999</b>	Access after entering PIN-Code 9999

<b>PIN PARAMETER</b>		
This parameter defines the PIN-code for lock function of all parameters (master PIN 6079).		
	<b>0000</b>	No lock
	...	
	<b>9999</b>	Parameterization of the unit after entering PIN-code 9999

<b>FACTORY SETTINGS</b>		
0	<b>NO</b>	No default values are loaded
1	<b>YES</b>	Load default values of all parameters (grey marked default values)

## 5.2. SSI Properties

<b>MODE</b>		
SSI setting master mode or slave		
0	<b>MASTER</b>	Master-Mode: Clock for SSI encoder comes from the device
1	<b>SLAVE</b>	Slave-Mode: Clock for SSI encoder comes from the external master.

<b>ENCODER RESOLUTION</b>		
Resolution of the SSI encoder (total number of bits)		
	10	Smallest value
	<b>25</b>	Default value
	32	Highest value

<b>BIT PER REVOLUTION</b>		
Bit revolution for singleturn		
	10	Smallest value
	<b>13</b>	Default value
	16	Highest value

<b>DATA FORMAT</b>		
Setting the SSI code (binary or grey)		
0	<b>GRAY CODE</b>	SSI-Code Gray
1	<b>BINARY CODE</b>	SSI-Code Binary

<b>BAUD RATE</b>		
Clock frequency of SSI telegrams		
0	<b>2 MHZ</b>	N.A.
1	<b>1.5 MHZ</b>	N.A.
2	<b>1 MHZ</b>	Clock frequency 1 MHz
3	<b>500 KHZ</b>	Clock frequency 500 kHz
4	<b>250 KHZ</b>	Clock frequency 250 kHz
5	<b>100 KHZ</b>	Clock frequency 100 kHz

Continuation „SSI Properties“:

**HIGH BIT** (for bit blanking)

Defines the highest evaluated bit (MSB) for bit blanking.

If all bits should be evaluated, HIGH BIT must be set to the given total number of bit.

	<b>01</b>	Smallest value
	<b>25</b>	Default value
	<b>32</b>	Highest value

**LOW BIT** (for bit blanking))

Defines the lowest evaluated bit (MSB) for bit blanking.

If all bits should be evaluated, LOW BIT must be set to 01.

	<b>01</b>	Smallest value
	...	
	<b>32</b>	Highest value

**SSI OFFSET**

In the case of a reset/Set value command (via keyboard command, control input or PC user interface) The current SSI position of the encoder is transferred to the parameter "SSI offset".

	<b>-99999999</b>	Smallest value
	<b>0</b>	Default value
	<b>99999999</b>	Highest value

**DIRECTION**

Definition of the direction of rotation forward / backward

	<b>0</b>	<b>FORWARD</b>	Forward
	<b>1</b>	<b>REVERSE</b>	Backwards

**ROUND LOOP VALUE**

Defines the number of encoder steps when a round-loop function is desired.

	<b>0</b>	Normal display of encoder data, round-loop function is turned off
	...	
	<b>99999999</b>	Number of steps for the round-loop function

**SAMPLING TIME (S)**

Determines the read cycle for the SSI signal in the Master MODE

	<b>0.001</b>	Minimum measurement time in seconds
	<b>0.010</b>	Default value
	<b>9.999</b>	Maximum measurement time in seconds

Continuation „SSI Properties“:

<b>ERROR BIT</b>		
Defines the encoder monitoring and the error bit		
	<b>0</b>	No error bit available. Review on connected sensor is turned off.
	...	
	<b>32</b>	Position of the error bits to be evaluated Review on connected sensor is turned on.

<b>ERROR POLARITY</b>		
Defined the polarity of the error bit in the case of an error		
	<b>0</b>	Bit is low in the case of an error
	<b>1</b>	Bit is high in the case of an error

<b>ENCODER SUPPLY</b> (available only at IX355)		
This parameter defines the output voltage of the auxiliary output (aux out)		
	<b>0</b>	<b>24VDC SUPPLY</b> 24 VDC encoder supply
	<b>1</b>	<b>5VDC SUPPLY</b> 5 VDC encoder supply

## 5.3. Preselection Values

This menu is used to set the preselection values or the switching points.

The preselection values / switching points are always referred to the display value.

This menu is only available for devices with option CO, AO or RL.

### PRESELECTION 1

Preselection / switching point 1

	-99999999	Smallest value
	1000	Default value
	+99999999	Highest value

### PRESELECTION 2

Preselection / switching point 2

	-99999999	Smallest value
	2000	Default value
	+99999999	Highest value

### PRESELECTION 3

Preselection / switching point 3

	-99999999	Smallest value
	3000	Default value
	+99999999	Highest value

### PRESELECTION 4

Preselection / switching point 4

If the BATCH MODE is active, the batch counter is compared with the preselection value 4.

	-99999999	Smallest value
	40000	Default value
	+99999999	Highest value



## 5.4. Preselection 1 Menu

This function is only available for devices with option CO, AO or RL.

MODE 1		
Switching conditions for preselection 1. Output/ relay/ display switches under the following conditions:		
0	$ \text{RESULT}  \geq  \text{PRES} $	<p>Absolute value of the display value is greater or equal absolute value of PRESELECTION 1</p> <p>With HYSTERESIS 1 not equal 0 the following switching condition is applied:            Display value <math>\geq</math> PRESELECTION 1 <math>\rightarrow</math> ON,            Display value <math>&lt;</math> PRESELECTION 1 – HYSTERESIS 1 <math>\rightarrow</math> OFF</p>
1	$ \text{RESULT}  \leq  \text{PRES} $	<p>Absolute value of the display value is less or equal absolute value of PRESELECTION 1 (start-up suppression (START UP DELAY) is advisable)</p> <p>With HYSTERESIS 1 not equal 0 the following switching condition is applied:            Display value <math>\leq</math> PRESELECTION 1 <math>\rightarrow</math> ON,            Display value <math>&gt;</math> PRESELECTION 1 + HYSTERESIS 1 <math>\rightarrow</math> OFF</p>
2	$ \text{RESULT}  =  \text{PRES} $	<p>Absolute value of the display value is equal absolute value of PRESELECTION 1</p> <p>A range (Preselection +/- ½ Hysteresis) can be defined and monitored in conjunction with the hysteresis.</p> <p>With HYSTERESIS 1 not equal 0 the following switching condition is applied:            Display value <math>&gt;</math> PRESELECTION 1 + ½ HYSTERESIS 1 <math>\rightarrow</math> OFF,            Display value <math>&lt;</math> PRESELECTION 1 - ½ HYSTERESIS 1 <math>\rightarrow</math> OFF</p>
3	$\text{RESULT} \geq \text{PRES}$	<p>Display value is greater or equal PRESELECTION 1, e.g. overspeed</p> <p>With HYSTERESIS 1 not equal 0 the following switching condition is applied:            Display value <math>\geq</math> PRESELECTION 1 <math>\rightarrow</math> ON,            Display value <math>&lt;</math> PRESELECTION 1 – HYSTERESIS 1 <math>\rightarrow</math> OFF</p>
4	$\text{RESULT} \leq \text{PRES}$	<p>Display value is less or equal PRESELECTION 1, e.g. underspeed (start-up suppression (START UP DELAY) is advisable)</p> <p>With HYSTERESIS 1 not equal 0 the following switching condition is applied:            Display value <math>\leq</math> PRESELECTION 1 <math>\rightarrow</math> ON,            Display value <math>&gt;</math> PRESELECTION 1 + HYSTERESIS 1 <math>\rightarrow</math> OFF</p>
5	$\text{RESULT} = \text{PRES}$	<p>Display value is equal PRESELECTION 1. A range (Preselection +/- ½ Hysteresis) can be defined and monitored in conjunction with the hysteresis.</p> <p>With HYSTERESIS 1 not equal 0 the following switching condition is applied:            Display value <math>&gt;</math> PRESELECTION 1 + ½ HYSTERESIS 1 <math>\rightarrow</math> OFF,            Display value <math>&lt;</math> PRESELECTION 1 - ½ HYSTERESIS 1 <math>\rightarrow</math> OFF</p>
6	$\text{RES} \geq \text{PRES-TRAIL}$	<p>Trailing PRESELECTION 1:            Display value is greater or equal PRESELECTION 2 – PRESELECTION 1 <math>\rightarrow</math> ON,            PRESELECTION 1 is the trailing value from PRESELECTION 2</p>
7	ERROR SET	Error message for device errors

Continuation „Preselection 1 Menu“:

<b>HYSTERESIS 1</b>		
This parameter defines the switching hysteresis of the switch-off point for preselection 1		
	<b>0</b>	No switching hysteresis
	...	
	<b>99999</b>	Switching hysteresis of 99999

<b>PULSE TIME 1 (S)</b>		
Duration of output pulse for the switching condition of preselection 1		
	<b>0,000</b>	No output pulse (static signal)
	...	
	<b>60,000</b>	Pulse duration of 60 seconds

<b>OUTPUT TARGET 1</b>		
Assignment of an output or relay for the switching condition of preselection 1. If more than one switching condition is assigned to one output / relay, the output is set when at least one switching condition is true		
	<b>0 NO</b>	No assignment
	<b>1 CTRL OUT 1</b>	Switching condition assigned to "Ctrl. Out 1"
	<b>2 CTRL OUT 2</b>	Switching condition assigned to "Ctrl. Out 2"
	<b>3 CTRL OUT 3</b>	Switching condition assigned to "Ctrl. Out 3"
	<b>4 CTRL OUT 4</b>	Switching condition assigned to "Ctrl. Out 4"
	<b>5 RELAY 1</b>	Switching condition assigned to "Rel. 1"
	<b>6 RELAY 2</b>	Switching condition assigned to "Rel. 2"

<b>OUTPUT POLARITY 1</b>		
Polarity for the switching condition of preselection 1		
	<b>0 ACTIVE HIGH</b>	Switching condition is true → Active „HIGH“
	<b>1 ACTIVE LOW</b>	Switching condition is true → Active „LOW“

<b>OUTPUT LOCK 1</b>		
Latch for the switching condition of preselection 1		
	<b>0 NO</b>	No latch for preselection
	<b>1 YES</b>	Latch for preselection (command LOCK RELEASE will clear latch)

Continuation „Preselection 1 Menu“:

<b>START UP DELAY 1 (S)</b>		
Start-up suppression for the switching condition of preselection 1. Time to start the monitoring function. This adjustment is only valid for the switching condition $ RESULT  \leq  PRES $ or $RESULT \leq PRES$ and mode SPPED and PROCESS TIME.		
(Start Up Delay 3 and 4 have an automatic start up suppression).		
	<b>0.000</b>	No start-up suppression
	...	
	<b>60.000</b>	Start-up suppression in seconds

<b>EVENT COLOR 1</b>		
Event-depending change of the display color for the switching condition of preselection 1. EVENT COLOR 1 has the lowest priority. EVENT COLOR 2 ... 4 are allowed to overwrite this color change.		
<b>0</b>	<b>NO CHANGE</b>	No color change.
<b>1</b>	<b>CHANGE TO RED</b>	Color change to red
<b>2</b>	<b>CHANGE TO GREEN</b>	Color change to green
<b>3</b>	<b>CHANGE TO YELLOW</b>	Color change to yellow

## 5.5. Preselection 2 Menu

### MODE 2

Switching conditions for preselection 2., see chapter PRESELECTION 1 MENU (except the trailing value)

		see chapter PRESELECTION 1 MENU
6	RES $\geq$ PRES-TRAIL	Trailing preselection 2: Display value is greater or equal to PRESELECTION 1 – PRESELECTION 2 → ON, PRESELECTION 2 is the trailing preselection from PRESELECTION 1.

### HYSTERESIS 2

This parameter defines the switching hysteresis of the switch-off point for preselection 2.  
See chapter PRESELECTION 1 MENU.

### PULSE TIME 2 (S)

Duration of output pulse for the switching condition of preselection 2.  
See chapter PRESELECTION 1 MENU.

### OUTPUT TARGET 2

Assignment of an output or relay for the switching condition of preselection 2.  
See chapter PRESELECTION 1 MENU.

### OUTPUT POLARITY 2

Polarity for the switching condition of preselection 2.  
See chapter PRESELECTION 1 MENU.

### OUTPUT LOCK 2

Latch for the switching condition of preselection 2.  
See chapter PRESELECTION 1 MENU.

### START UP DELAY 2 (S)

Start-up suppression for the switching condition of preselection 2.  
See chapter PRESELECTION 1 MENU.  
(Start Up Delay 3 and 4 have an automatic start up suppression).

### EVENT COLOR 2

Event-dependent change of the display color for the switching condition of preselection 2.  
See chapter PRESELECTION 1 MENU.

## 5.6. Preselection 3 Menu

### MODE 3

Switching conditions for preselection 3., see chapter PRESELECTION 1 MENU (except the trailing value)

		See chapter PRESELECTION 1 MENU
6	RES>=PRES-TRAIL	Trailing preselection 3: Display value is greater or equal to PRESELECTION 4 – PRESELECTION 3 → ON, PRESELECTION 3 is the trailing preselection from PRESELECTION 4.

### HYSTERESIS 3

This parameter defines the switching hysteresis of the switch-off point for preselection 3.  
See chapter PRESELECTION 1 MENU.

### PULSE TIME 3 (S)

Duration of output pulse for the switching condition of preselection 3.  
See chapter PRESELECTION 1 MENU.

### OUTPUT TARGET 3

Assignment of an output or relay for the switching condition of preselection 3.  
See chapter PRESELECTION 1 MENU.

### OUTPUT POLARITY 3

Polarity for the switching condition of preselection 3.  
See chapter PRESELECTION 1 MENU.

### OUTPUT LOCK 3

Latch for the switching condition of preselection 3.  
See chapter PRESELECTION 1 MENU.

### START UP DELAY 3

Start-up suppression for the switching condition of preselection 3.  
Time to start the monitoring function.

This adjustment is only valid for the switching condition  $|\text{RESULT}| \leq |\text{PRES}|$  or  $\text{RESULT} \leq \text{PRES}$  and mode SPPED and PROCESS TIME. (Start Up Delay 1 and 2 have a time-dependent start up suppression).

0	OFF	No start-up suppression
1	AUTO	Automatic start up suppression, Until the preselection value / switching point is exceeded for the first time.

### EVENT COLOR 3

Event-depending change of the display color for the switching condition of preselection 3.  
See chapter PRESELECTION 1 MENU.

## 5.7. Preselection 4 Menu

If the BATCH MODE is active, the batch counter is compared with the preselection value 4.

<b>MODE 4</b>		
Switching conditions for preselection 4., see chapter PRESELECTION 1 MENU (except the trailing value)		
		See chapter PRESELECTION 1 MENU
6	RES>=PRES-TRAIL	Trailing preselection 4: Display value is greater or equal to PRESELECTION 3 – PRESELECTION 4 → ON, PRESELECTION 4 is the trailing preselection from PRESELECTION 3.

<b>HYSTERESIS 4</b>		
This parameter defines the switching hysteresis of the switch-off point for preselection 4. See chapter PRESELECTION 1 MENU.		

<b>PULSE TIME 4 (S)</b>		
Duration of output pulse for the switching condition of preselection 4. See chapter PRESELECTION 1 MENU.		

<b>OUTPUT TARGET 4</b>		
Assignment of an output or relay for the switching condition of preselection 4. See chapter PRESELECTION 1 MENU.		

<b>OUTPUT POLARITY 4</b>		
Polarity for the switching condition of preselection 4. See chapter PRESELECTION 1 MENU.		

<b>OUTPUT LOCK 4</b>		
Latch for the switching condition of preselection 4. See chapter PRESELECTION 1 MENU.		

<b>START UP DELAY 4</b>		
Start-up suppression for the switching condition of preselection 4. See chapter PRESELECTION 3 MENU. (Start Up Delay 1 and 2 have a time-dependent start up suppression).		
0	OFF	No start-up suppression
1	AUTO	Automatic start up suppression, Until the preselection value / switching point is exceeded for the first time.

<b>EVENT COLOR 4</b>		
Event-dependending change of the display color for the switching condition of preselection 4. See chapter PRESELECTION 1 MENU.		

## 5.8. Serial Menu

This menu defines the basic settings of serial interface.

This function is only available for devices with option CO or AO.

<b>UNIT NUMBER</b>		
This parameter defines serial device addresses. The addresses between 11 and 99 can be assigned to the devices. Addresses with zero are not allowed, there are used as broadcast addresses.		
	<b>11</b>	Smallest address
	...	
	<b>99</b>	Highest address

<b>SERIAL BAUD RATE</b>		
This parameter defines the serial baud rate		
	<b>0</b>	<b>9600</b> 9600 baud
	<b>1</b>	<b>19200</b> 19200 baud
	<b>2</b>	<b>38400</b> 38400 baud

<b>SERIAL FORMAT</b>					
This parameter defines the bit data format.					
	<b>0</b>	<b>7-EVEN-1</b>	7 data	Parity even	1 Stop
	<b>1</b>	<b>7-EVEN-2</b>	7 data	Parity even	2 Stops
	<b>2</b>	<b>7-ODD-1</b>	7 data	Parity odd	1 Stop
	<b>3</b>	<b>7-ODD-2</b>	7 data	Parity odd	2 Stops
	<b>4</b>	<b>7-NONE-1</b>	7 data	no Parity	1 Stop
	<b>5</b>	<b>7-NONE-2</b>	7 data	no Parity	2 Stops
	<b>6</b>	<b>8-EVEN-1</b>	8 data	Parity even	1 Stop
	<b>7</b>	<b>8-ODD-1</b>	8 data	Parity odd	1 Stop
	<b>8</b>	<b>8-NONE-1</b>	8 data	no Parity	1 Stop
	<b>9</b>	<b>8-NONE-2</b>	8 data	no Parity	2 Stops

<b>SERIAL INIT</b>		
This parameter defines the baud rate for the initialization to the user interface OS6.0. With settings larger than 9600 the initialization time can be reduced.		
	<b>0</b>	<b>NO</b> Initialization with 9600 baud. Then the device operates with the value selected by the user.
	<b>1</b>	<b>YES</b> Initialization with the baud rate set by SERIAL BAUD RATE. Then the device operates with the value selected by the user.

Continuation „Serial Menu“:

<b>SERIAL PROTOCOL</b>														
Determines the sequence of characters send, when using the serial output for cyclic data transmission under time control (xxxxxxx = value SERIAL VALUE). Setting „1“ removes the unit address from the string which allows a slight faster transmission cycle.														
<b>0</b>	Transmission report = Unit No., +/-, data, LF, CR <table border="1" style="margin-left: 40px;"> <tr> <td>1</td><td>1</td><td>+/-</td><td>X</td><td>X</td><td>X</td><td>X</td><td>X</td><td>X</td><td>X</td><td>LF</td><td>CR</td> </tr> </table>		1	1	+/-	X	X	X	X	X	X	X	LF	CR
1	1	+/-	X	X	X	X	X	X	X	LF	CR			
<b>1</b>	Transmission report = +/-, data, LF, CR <table border="1" style="margin-left: 40px;"> <tr> <td>+/-</td><td>X</td><td>X</td><td>X</td><td>X</td><td>X</td><td>X</td><td>X</td><td>X</td><td>LF</td><td>CR</td> </tr> </table>		+/-	X	X	X	X	X	X	X	X	LF	CR	
+/-	X	X	X	X	X	X	X	X	LF	CR				

<b>SERIAL TIMER (S)</b>		
This register determines the cycle time in seconds for cycling transmission of SERIAL VALUE when using the serial output. (On a serial request, the cycling transmission is stopped for 20 s)		
<b>0,000</b>	All cyclic transmission is switched off. The unit will send data upon a serial request or with command SERIAL PRINT.	
...		
<b>60,000</b>	Cycle time in seconds.	

<b>SERIAL VALUE</b>			
This parameter defines the value to be transmitted.			
Setting	Code	Register contents	
<b>0</b>	:0	Measurement Result	
<b>1</b>	:1	SSI Data	
<b>2</b>	:2	SSI Single	
<b>3</b>	:3	SSI Rev	
<b>4</b>	:4	SSI Dir Result	
<b>5</b>	:5	SSI Mask Result	
<b>6</b>	:6	Minimal Value	
<b>7</b>	:7	Maximal Value	
<b>8</b>	:8	SSI Set Result	
<b>9</b>	:9	SSI Data	



## 5.9. Analog Menu

This menu defines the basic settings of the analog output.

This function is only available for devices with option AO.

<b>ANALOG FORMAT</b>		
This parameter defines the output characteristics. The analogue output is proportional to the display value. With setting ANALOG FORMAT (-10 ... +10 V) in MODE COUNTER the polarity of the analog output depends on the polarity of the display value.		
0	-10...10V	-10 ... +10 V
1	0...20MA	0 ... 20 mA
2	4...20MA	4 ... 20 mA

<b>ANALOG START</b>		
This parameter defines the start value of the analog conversion. This start value is corresponding to the display value for an analog output of 0 V or 0/4 mA.		
	-99999999	Smallest start value
	0	Default value
	+99999999	Highest start value

<b>ANALOG END</b>		
This parameter defines the end value of the analog conversion. This end value is corresponding to the display value for an analog output of (+/-) 10 V or 20mA.		
	-99999999	Smallest end value
	10000	Default Wert
	+99999999	Highest end value

<b>ANALOG GAIN (%)</b>		
This parameter defines the zero offset of the analog output. The ANALOG GAIN is the maximum modulation of the analog output in % terms given up to (+/-) 10 V or 20 mA.		
E.g. 102,00 results in an offset of 10.2 V / 20.4 mA from reaching the ANALOG START value		
E.g. 95,00 results in an offset of 9.5 V / 18 mA from reaching the ANALOG END value		
	0,00	Smallest end value
	100,00	Default Wert
	110,00	Highest end value

<b>ANALOG OFFSET (%)</b>		
This parameter defines the zero offset of the analog output.		
E. g. 0.20 results in an offset of 0.02 V or 0.04 mA from reaching the ANALOG START value		
	-99,99	Smallest offset
	0	Default value
	+99,00	Highest offset

## 5.10. Command Menu

### INPUT 1 ACTION\_(function Input 1)

This parameter defines the function of the input "Ctrl. In 1".

0	NO	No function	
1	RESET/SET VALUE	Transfer of the current SSI position to the SSI offset parameter	(d) (s)
2	FREEZE	Freeze actual display value	(s)
3	KEY LOCK	disable touch screen	(s)
4	LOCK RELEASE	Loosen locking of all outputs / relay	(d)
5	RESET MIN/MAX	Reset of the min. / max. values	(d) (s)
6	SERIAL PRINT	Sending of serial data, see parameter SERIAL VALUE	(d)
7	TEACH PRESEL. 1	Current display value is stored as PRESELECTION 1	(d)
8	TEACH PRESEL. 2	Current display value is stored as PRESELECTION 2	(d)
9	TEACH PRESEL. 3	Current display value is stored as PRESELECTION 3	(d)
10	TEACH PRESEL. 4	Current display value is stored as PRESELECTION 4	(d)
11	SCROLL DISPLAY	Display switching (see display in operation mode)	(d)
12	CLEAR LOOP TIME	Release all latched switching conditions	
13	START PRESELECT	N.A.	
14	ACTIVATE DATA	N.A.	
15	STORE DATA	N.A.	
16	TESTPROGRAM	N.A.	
17	SET RED COLOR	The display lights up red. The color can be changed by the event-dependent color switching in the PRESELECTION 1... 4	(d)
18	SET GREEN COLOR	The display lights up green. The color can be changed by the event-dependent color switching in the PRESELECTION 1... 4	(d)
19	SET YELLOW COLOR	The display lights up yellow The color can be changed by the event-dependent color switching in the PRESELECTION 1... 4	(d)

(s) = static switching (level evaluation)  
 INPUT CONFIG must be set to active LOW / HIGH

(d) = dynamic switching (edge evaluation)  
 INPUT CONFIG must be set to RISING/FALLING EDGE

Continuation „Command Menu“:

### INPUT 1 CONFIG

This parameter defines the switching characteristics of the input “Ctrl. In 1”.

0	ACTIVE LOW	Active at „LOW“ (static)
1	ACTIVE HIGH	Active at „HIGH“ (static)
2	RISING EDGE	Activate at rising edge
3	FALLING EDGE	Activate at falling edge

### INPUT 2 ACTION

This parameter defines the function of the input “Ctrl. In 2”.

See parameter INPUT 1 ACTION.

### INPUT 2 CONFIG

This parameter defines the switching characteristics of the input “Ctrl. In 2”.

See parameter INPUT 1 CONFIG.

### INPUT 3 ACTION

This parameter defines the function of the input “Ctrl. In 3”.

See parameter INPUT 1 ACTION.

### INPUT 3 CONFIG

This parameter defines the switching characteristics of the input “Ctrl. In 3”.

See parameter INPUT 1 CONFIG.

## 5.11. Display Menu

Parameter changes become active only after closing the menu selection.

### COLOR

This parameter defines the display color.

Event-depending change of the display color by a switching condition is possible (see PRESELECTION 1...4 MENU)

Event-depending changes are only available for devices with option CO, AO or RL.

	<b>0</b>	<b>RED</b>	Red display
	<b>1</b>	<b>GREEN</b>	Green display
	<b>2</b>	<b>YELLOW</b>	Yellow display

### BRIGHTNESS (%)

This parameter defines the brightness of the display in percent

	<b>10</b>	Min. brightness
	<b>90</b>	Default value
	<b>100</b>	Max. brightness

### CONTRAST

This parameter defines the viewing angle.

	<b>0</b>	Viewing angle from top
	<b>1</b>	Viewing angle from centre
	<b>2</b>	Viewing angle from bottom

### SCREEN SAVER (S)

This parameter defines the time in seconds until the display is switched off, after the last touch action.

A new touch action will activate the display again.

	<b>0</b>	No switch off
	...	
	<b>9999</b>	Longest time to switch off

### UP-DATE-TIME (S)

This parameter defines the update time in seconds of the display only.

	<b>0,005</b>	Shortest update time
	<b>0,1</b>	Default value
	<b>9,999</b>	Longest update time

### FONT

This parameter defines the setting of the font style.

	<b>0</b>	Standard
	<b>1</b>	Font 1

## 5.12. Linearization Menu

The linearization function is defined in this menu. This menu will only be showed, if the LINEARIZATION MODE in GENERAL MENU is selected.

Linearization description and examples are shown in the appendix.

### P1(X) ... P24(X)

X-coordinate of the linearization point.

This value representing the display value which the unit show in the display without linearization.

	-99999999	Smallest X-coordinate
	0	Default value
	+99999999	Largest X-coordinate

### P1(Y) ... P24(Y)

Y-coordinate of the linearization point

This is the display value, which the unit should show in the display with linearization.

E.g. P2(X) is replaced by P2(Y).

	-99999999	Smallest Y-coordinate
	0	Default value
	+99999999	Largest Y-coordinate

# 6. Appendix

## 6.1. Data readout via serial interface

All codes shown in the parameter SERIAL VALUE are available for serial readout by PC or PLC. For communication the monitors use the Drivecom Protocol according to ISO 1745. All protocol details can be found in our manual SERPRO which is available for download from our homepage [www.motrona.com](http://www.motrona.com).

**To request for a data transmission you must send the following request string to the converter:**

EOT	AD1	AD2	C1	C2	ENQ
-----	-----	-----	----	----	-----

EOT = control character (Hex 04)

AD1 = unit address, High Byte

AD2 = unit address, Low Byte

C1 = register code, High Byte

C2 = register code, Low Byte

ENQ = control character (Hex 05)

The following example shows the request string for readout of the actual input frequency of a monitor (Code=1) from a unit with unit address 11:

ASCII-Code:	ASCII-Code:	EOT	1	1	:	1	ENQ
Hex-Code:	Hexadecimal:	04	31	31	3A	31	05
Binary-Code:	Binary:	0000 0100	0011 0001	0011 0001	0011 1010	0011 0001	0000 0101

**After a correct request, the unit will respond:**

STX	C1	C2	xxxxx	ETX	BCC
-----	----	----	-------	-----	-----

STX = control character (Hex 02)

C1 = register code, High Byte

C2 = register code, Low Byte

xxxxx = readout data

ETX = control character (Hex 03)

BCC = block check character

## 6.2. Parameter / serial codes

#	Menu	Name	Serial Code	Min	Max	Default
0	GENERAL MENU	DISPLAY FORMAT	0	0	2	0
1	GENERAL MENU	FACTOR	1	-99999999	99999999	1
2	GENERAL MENU	DIVIDER	2	-99999999	99999999	1
3	GENERAL MENU	ADDITIVE VALUE	3	-99999999	99999999	0
4	GENERAL MENU	DECIMAL POINT	4	0	7	0
5	GENERAL MENU	SCALE UNITS	5	0	28	0
6	GENERAL MENU	LINIARIZATION MODE	6	0	2	0
7	GENERAL MENU	PIN PRESELECTION	7	0	9999	0
8	GENERAL MENU	PIN PARAMETER	8	0	9999	0
9	GENERAL MENU	FACTORY SETTINGS	9	0	1	0
10	GENERAL MENU	-	10	0	0	0
11	GENERAL MENU	-	11	0	0	0
12	GENERAL MENU	-	12	0	0	0
13	GENERAL MENU	-	13	0	0	0
14	SSI PROPERTIES	MODE	14	0	1	0
15	SSI PROPERTIES	ENCODER RESOLUTION	15	10	32	25
16	SSI PROPERTIES	BIT PER REVOLUTION	16	10	16	13
17	SSI PROPERTIES	DATA FORMAT	17	0	1	0
18	SSI PROPERTIES	BAUD RATE	18	0	5	3
19	SSI PROPERTIES	HIGH BIT	19	1	32	25
20	SSI PROPERTIES	LOW BIT	20	1	32	1
21	SSI PROPERTIES	SET VALUE	21	-99999999	99999999	0
22	SSI PROPERTIES	DIRECTION	22	0	1	0
23	SSI PROPERTIES	ROUND LOOP VAUE	23	0	99999999	0
24	SSI PROPERTIES	SAMPLING TIME (S)	24	1	9999	10
25	SSI PROPERTIES	ERROR BIT	25	0	32	0
26	SSI PROPERTIES	ERROR POLARITY	26	0	1	0
27	SSI PROPERTIES	ENCODER SUPPLY	27	0	1	0
28	SSI PROPERTIES	-	28	0	0	0
29	SSI PROPERTIES	-	29	0	0	0
30	PRESELECTION VALUES	PRESELECTION 1	A0	-99999999	99999999	1000
31	PRESELECTION VALUES	PRESELECTION 2	A1	-99999999	99999999	2000
32	PRESELECTION VALUES	PRESELECTION 3	A2	-99999999	99999999	3000
33	PRESELECTION VALUES	PRESELECTION 4	A3	-99999999	99999999	4000
34	PRESELECTION 1 MENU	MODE 1	A4	0	9	0
35	PRESELECTION 1 MENU	HYSTERESIS 1	A5	0	99999	0
36	PRESELECTION 1 MENU	PULSE TIME 1 (S)	A6	0	60000	0
37	PRESELECTION 1 MENU	OUTPUT TARGET 1	A7	0	6	1
38	PRESELECTION 1 MENU	OUTPUT POLARITY 1	A8	0	1	0
39	PRESELECTION 1 MENU	OUTPUT LOCK 1	A9	0	1	0
40	PRESELECTION 1 MENU	START UP DELAY 1 (S)	B0	0	60000	0
41	PRESELECTION 1 MENU	EVENT COLOR 1	B1	0	3	0
42	PRESELECTION 1 MENU	-	B2	0	0	0
43	PRESELECTION 1 MENU	-	B3	0	0	0

## Continuation „Parameterliste“:

#	Menu	Name	Serial Code	Min	Max	Default
44	PRESELECTION 2 MENU	MODE 2	B4	0	9	0
45	PRESELECTION 2 MENU	HYSTERESIS 2	B5	0	99999	0
46	PRESELECTION 2 MENU	PULSE TIME 2 (S)	B6	0	60000	0
47	PRESELECTION 2 MENU	OUTPUT TARGET 2	B7	0	6	2
48	PRESELECTION 2 MENU	OUTPUT POLARITY 2	B8	0	1	0
49	PRESELECTION 2 MENU	OUTPUT LOCK 2	B9	0	1	0
50	PRESELECTION 2 MENU	START UP DELAY 2 (S)	C0	0	60000	0
51	PRESELECTION 2 MENU	EVENT COLOR 2	C1	0	3	0
52	PRESELECTION 2 MENU	-	C2	0	0	0
53	PRESELECTION 2 MENU	-	C3	0	0	0
54	PRESELECTION 3 MENU	MODE 3	C4	0	9	0
55	PRESELECTION 3 MENU	HYSTERESIS 3	C5	0	99999	0
56	PRESELECTION 3 MENU	PULSE TIME 3 (S)	C6	0	60000	0
57	PRESELECTION 3 MENU	OUTPUT TARGET 3	C7	0	6	3
58	PRESELECTION 3 MENU	OUTPUT POLARITY 3	C8	0	1	0
59	PRESELECTION 3 MENU	OUTPUT LOCK 3	C9	0	1	0
60	PRESELECTION 3 MENU	START UP DELAY 3	D0	0	1	0
61	PRESELECTION 3 MENU	EVENT COLOR 3	D1	0	3	0
62	PRESELECTION 3 MENU	-	D2	0	0	0
63	PRESELECTION 3 MENU	-	D3	0	0	0
64	PRESELECTION 4 MENU	MODE 4	D4	0	9	0
65	PRESELECTION 4 MENU	HYSTERESIS 4	D5	0	99999	0
66	PRESELECTION 4 MENU	PULSE TIME 4 (S)	D6	0	60000	0
67	PRESELECTION 4 MENU	OUTPUT TARGET 4	D7	0	6	4
68	PRESELECTION 4 MENU	OUTPUT POLARITY 4	D8	0	1	0
69	PRESELECTION 4 MENU	OUTPUT LOCK 4	D9	0	1	0
70	PRESELECTION 4 MENU	START UP DELAY 4	E0	0	1	0
71	PRESELECTION 4 MENU	EVENT COLOR 4	E1	0	3	0
72	PRESELECTION 4 MENU	-	E2	0	0	0
73	PRESELECTION 4 MENU	-	E3	0	0	0
74	SERIAL MENU	UNIT NUMBER	90	11	99	11
75	SERIAL MENU	SERIAL BAUD RATE	91	0	2	0
76	SERIAL MENU	SERIAL FORMAT	92	0	9	0
77	SERIAL MENU	SERIAL INIT	9~	0	1	0
78	SERIAL MENU	SERIAL PROTOCOL	E4	0	1	0
79	SERIAL MENU	SERIAL TIMER (S)	E5	0	60000	0
80	SERIAL MENU	SERIAL VALUE	E6	0	3	0
81	SERIAL MENU	-	E7	0	0	0
82	ANALOG MENU	ANALOG FORMAT	E8	0	2	0
83	ANALOG MENU	ANALOG START	E9	-99999999	99999999	0
84	ANALOG MENU	ANALOG END	F0	-99999999	99999999	10000
85	ANALOG MENU	ANALOG GAIN %	F1	0	11000	10000
86	ANALOG MENU	ANALOG OFFSET %	F2	-9999	9999	0
87	ANALOG MENU	-	F3	0	0	0
88	ANALOG MENU	-	F4	0	0	0



## Continuation „Parameterliste“:

#	Menu	Name	Serial Code	Min	Max	Default
89	COMMAND MENU	INPUT 1 ACTION	F5	0	22	0
90	COMMAND MENU	INPUT 1 CONFIG.	F6	0	3	2
91	COMMAND MENU	INPUT 2 ACTION	F7	0	22	0
92	COMMAND MENU	INPUT 2 CONFIG.	F8	0	3	2
93	COMMAND MENU	INPUT 3 ACTION	F9	0	22	0
94	COMMAND MENU	INPUT 3 CONFIG.	G0	0	3	2
95	COMMAND MENU	-	G1	0	0	0
96	COMMAND MENU	-	G2	0	0	0
97	COMMAND MENU	-	G3	0	0	0
98	COMMAND MENU	-	G4	0	0	0
99	COMMAND MENU	-	G5	0	0	0
100	DISPLAY MENU	COLOR	G6	0	2	0
101	DISPLAY MENU	BRIGHTNESS %	G7	10	100	90
102	DISPLAY MENU	CONTRAST	G8	0	2	1
103	DISPLAY MENU	SCREEN SAVER (S)	G9	0	9999	0
104	DISPLAY MENU	UP-DATE-TIME (S)	H0	5	9999	100
105	DISPLAY MENU	FONT	H1	0	1	0
106	DISPLAY MENU	-	H2	0	0	0
107	DISPLAY MENU	-	H3	0	0	0
108	DISPLAY MENU	-	H4	0	0	0
109	LINEARIZATION MENU	P1(X)	H5	-99999999	99999999	0
110	LINEARIZATION MENU	P1(Y)	H6	-99999999	99999999	0
111	LINEARIZATION MENU	P2(X)	H7	-99999999	99999999	0
112	LINEARIZATION MENU	P2(Y)	H8	-99999999	99999999	0
113	LINEARIZATION MENU	P3(X)	H9	-99999999	99999999	0
114	LINEARIZATION MENU	P3(Y)	I0	-99999999	99999999	0
115	LINEARIZATION MENU	P4(X)	I1	-99999999	99999999	0
116	LINEARIZATION MENU	P4(Y)	I2	-99999999	99999999	0
117	LINEARIZATION MENU	P5(X)	I3	-99999999	99999999	0
118	LINEARIZATION MENU	P5(Y)	I4	-99999999	99999999	0
119	LINEARIZATION MENU	P6(X)	I5	-99999999	99999999	0
120	LINEARIZATION MENU	P6(Y)	I6	-99999999	99999999	0
121	LINEARIZATION MENU	P7(X)	I7	-99999999	99999999	0
122	LINEARIZATION MENU	P7(Y)	I8	-99999999	99999999	0
123	LINEARIZATION MENU	P8(X)	I9	-99999999	99999999	0
124	LINEARIZATION MENU	P8(Y)	J0	-99999999	99999999	0
125	LINEARIZATION MENU	P9(X)	J1	-99999999	99999999	0
126	LINEARIZATION MENU	P9(Y)	J2	-99999999	99999999	0
127	LINEARIZATION MENU	P10(X)	J3	-99999999	99999999	0
128	LINEARIZATION MENU	P10(Y)	J4	-99999999	99999999	0
129	LINEARIZATION MENU	P11(X)	J5	-99999999	99999999	0
130	LINEARIZATION MENU	P11(Y)	J6	-99999999	99999999	0
131	LINEARIZATION MENU	P12(X)	J7	-99999999	99999999	0
132	LINEARIZATION MENU	P12(Y)	J8	-99999999	99999999	0
133	LINEARIZATION MENU	P13(X)	J9	-99999999	99999999	0
134	LINEARIZATION MENU	P13(Y)	K0	-99999999	99999999	0
135	LINEARIZATION MENU	P14(X)	K1	-99999999	99999999	0
136	LINEARIZATION MENU	P14(Y)	K2	-99999999	99999999	0

#	Menu	Name	Serial Code	Min	Max	Default
137	LINEARIZATION MENU	P15(X)	K3	-99999999	99999999	0
138	LINEARIZATION MENU	P15(Y)	K4	-99999999	99999999	0
139	LINEARIZATION MENU	P16(X)	K5	-99999999	99999999	0
140	LINEARIZATION MENU	P16(Y)	K6	-99999999	99999999	0
141	LINEARIZATION MENU	P17(X)	K7	-99999999	99999999	0
142	LINEARIZATION MENU	P17(Y)	K8	-99999999	99999999	0
143	LINEARIZATION MENU	P18(X)	K9	-99999999	99999999	0
144	LINEARIZATION MENU	P18(Y)	L0	-99999999	99999999	0
145	LINEARIZATION MENU	P19(X)	L1	-99999999	99999999	0
146	LINEARIZATION MENU	P19(Y)	L2	-99999999	99999999	0
147	LINEARIZATION MENU	P20(X)	L3	-99999999	99999999	0
148	LINEARIZATION MENU	P20(Y)	L4	-99999999	99999999	0
149	LINEARIZATION MENU	P21(X)	L5	-99999999	99999999	0
150	LINEARIZATION MENU	P21(Y)	L6	-99999999	99999999	0
151	LINEARIZATION MENU	P22(X)	L7	-99999999	99999999	0
152	LINEARIZATION MENU	P22(Y)	L8	-99999999	99999999	0
153	LINEARIZATION MENU	P23(X)	L9	-99999999	99999999	0
154	LINEARIZATION MENU	P23(Y)	M0	-99999999	99999999	0
155	LINEARIZATION MENU	P24(X)	M1	-99999999	99999999	0
156	LINEARIZATION MENU	P24(Y)	M2	-99999999	99999999	0

### Serial codes of commands:

Serial Code	Command
54	RESET/SET
55	FREEZE DISPLAY
56	TOUCH DISABLE
57	CLR LOCK
58	CLR MIN MAX
59	SERIAL PRINT
60	TEACH PRES 1
61	TEACH PRES 2
62	TEACH PRES 3
63	TEACH PRES 4
64	SCROLL_DISPLAY
65	CLEAR LOOP TIME
66	START PRESELECTION
67	ACTIVATE DATA
68	STORE EEPROM
69	TESTPROGRAMM

## 6.3. Linearization

The linearization function of this unit allows converting a linear input signal into a non-linear developing (or vice versa). There are 24 programmable x/y coordinates available, which can be set in any desired distance over the full conversion range. Between two coordinates, the unit uses linear interpolation. Therefore it is advisable to use more coordinates in a range with strong curves and only a few coordinates where the curvature is less.

To specify an individual linearization curve, the parameter LINEARISAZATION MODE must be set to either 1 QUADRANT or 4 QUADRANT (see following diagram).

The parameters P1(X) to P24(X) are used to specify the coordinates on the x-axis. These are the measuring values that the unit normally would generate according to the actual input signal.

Now enter the attached values to parameter P1(Y) to P24(Y). These are the values that the unit will generate instead of the x- values, i.e. P5(Y) replaces P5(X) etc.

The X-Coordinates must use continuously increasing settings, i.e. P1(X) must have the lowest and P24(X) must have the highest setting. If the measured value is bigger than the last defined X-value, the corresponding Y-value is displayed.

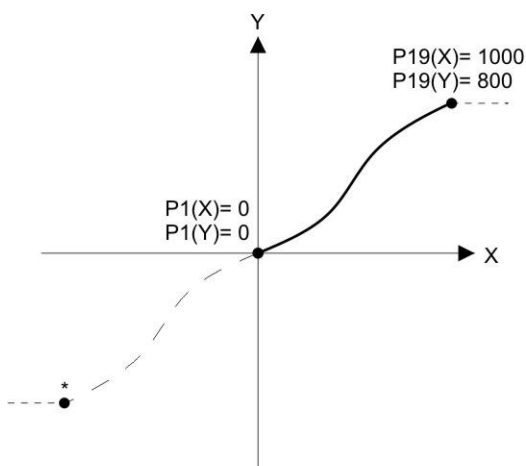

Example: Linearization Mode: 1 Quadrant

\* Linearization is point symmetric to 1. Quadrant

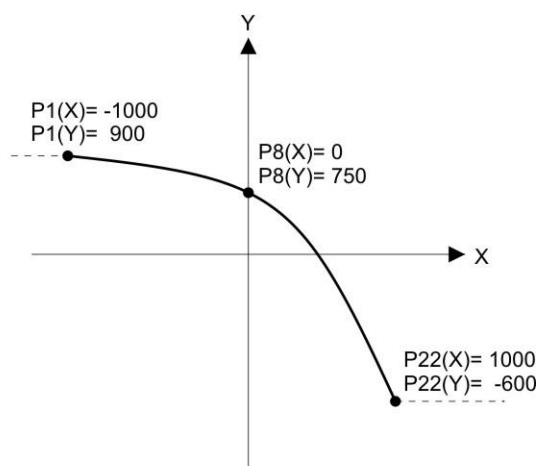

Example: Linearization Mode: 4 Quadrant

### Mode: 1 Quadrant:

P1(X) must be set to zero. Linearization is only defined in the positive range and the negative range will be mirrored symmetric to central point.

### Mode: 4 Quadrant:

P1(X) can also be set to a negative value. If the measured value is smaller than P1(X), P1(Y) is displayed.

Application Example:

The picture below shows a watergate where the opening is picked up by means of an incremental encoder. We would like to display the clearance of the gate "d", but the existing encoder information is proportional to the angular information  $\varphi$ .

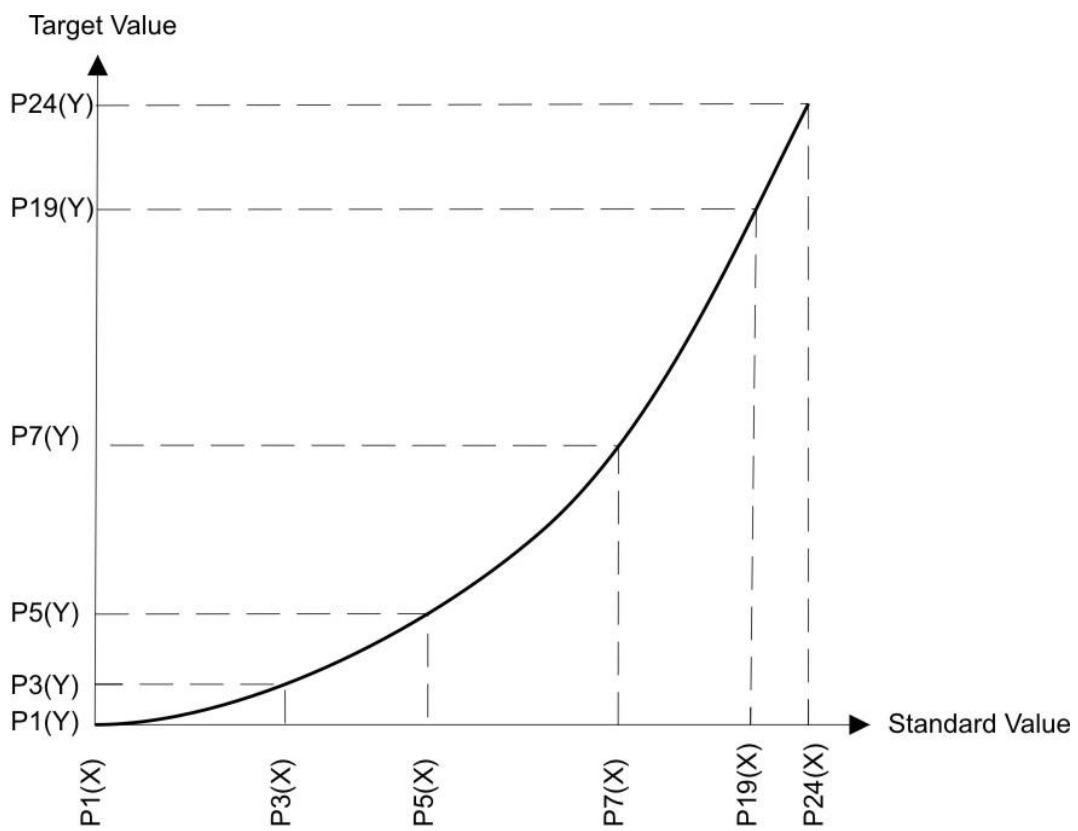
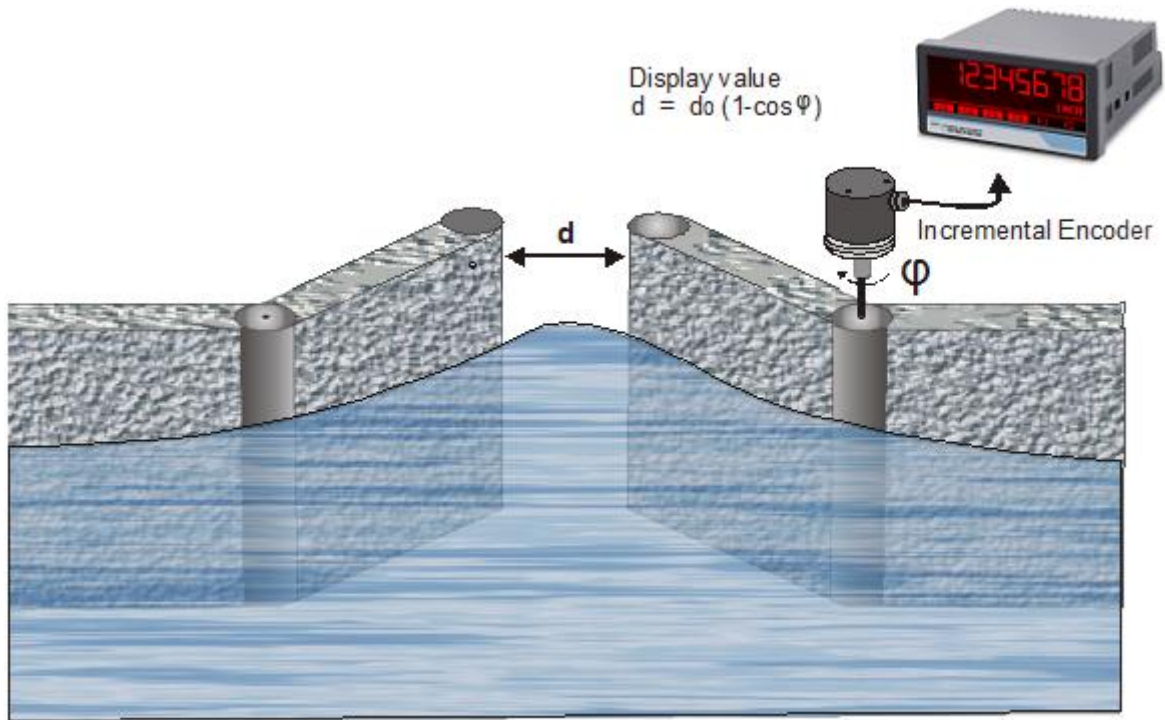

## 6.4. Reading SSI-Value

The received data is always filled to 32 bit data length.

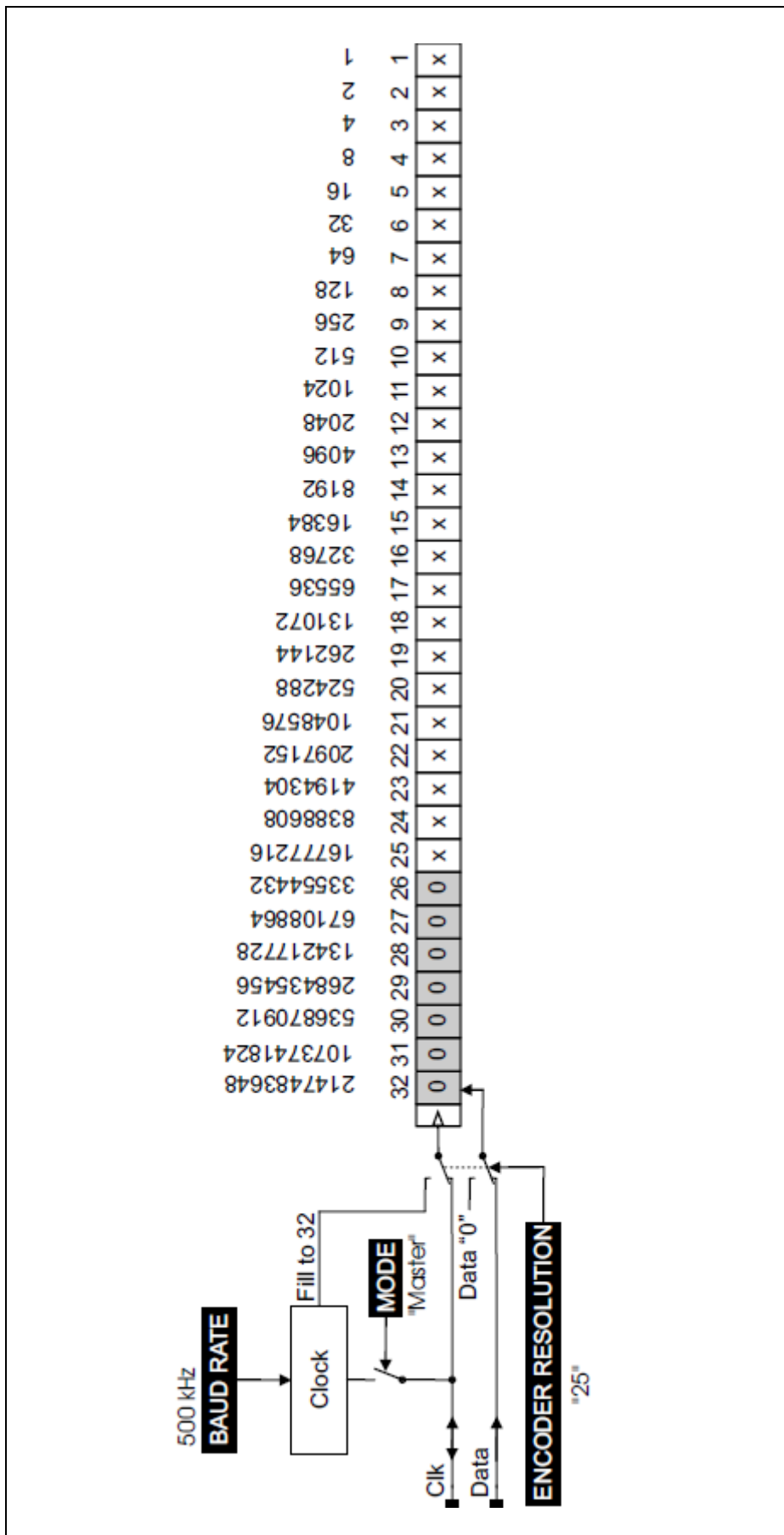

## 6.5. Internal processing and calculation of SSI data

<p>Checking the error bit:</p>	<p style="text-align: center;"><b>"25"</b> ERROR POLARITY ERROR BIT</p> <p style="text-align: center;">32 31 30 29 28 27 26 25 24 23 22 21 20 19 18 17 16 15 14 13 12 11 10 9 8 7 6 5 4 3 2 1</p> <p style="text-align: center;">0 0 0 0 0 0 0 y x x x x x x x x x x x x x x x x x x x x x x x x x x x x x x</p>
<p>Data Conversion: Grey Code → binary</p>	<p style="text-align: center;"><b>"grey"</b> DATA FORMAT</p> <p style="text-align: center;">32 31 30 29 28 27 26 25 24 23 22 21 20 19 18 17 16 15 14 13 12 11 10 9 8 7 6 5 4 3 2 1</p> <p style="text-align: center;">0 0 0 0 0 0 0 grey x x x x x x x x x x x x x x x x x x x x x x x x x x x x x x</p>
<p>Data splitting: Bit per revolution and number of revolutions</p>	<p style="text-align: center;"><b>"12"</b> BITS PER RESOLUTION</p> <p style="text-align: center;">RESOLUTIONS</p> <p style="text-align: center;">12 11 10 9 8 7 6 5 4 3 2 1 x x x x x x x x x x x x x</p> <p style="text-align: center;">24 23 22 21 20 19 18 17 16 15 14 13 x x x x x x x x x x x x x</p>
<p>Checking the direction of rotation</p>	<p style="text-align: center;"><b>"0"</b> DIRECTION</p> <p style="text-align: center;">32 31 30 29 28 27 26 25 24 23 22 21 20 19 18 17 16 15 14 13 12 11 10 9 8 7 6 5 4 3 2 1</p> <p style="text-align: center;">0 0 0 0 0 0 0 0 DIRECTION x x x x x x x x x x x x x x x x x x x x x x x x x x x x x x</p>

<p>Evaluation of the bit blanking</p>	<p>The diagram illustrates the bit evaluation for bit blanking. It shows two 32-bit registers. The top register has bits 32-20 set to 0, bits 19-8 set to X, and bits 7-0 set to 1. The bottom register has bits 32-16 set to 0, bits 15-8 set to X, and bits 7-0 set to 1. Arrows point from labels 'HIGH BIT' and 'LOW BIT' to the bit positions in the registers.</p>
<p>Considering SSI Offset</p>	<p>The diagram illustrates the SSI offset calculation. It shows two 32-bit registers. The top register has bits 32-20 set to 0, bits 19-16 set to 0, bits 15-12 set to Y, and bits 11-0 set to Y. The bottom register has bits 32-20 set to 0, bits 19-16 set to 0, bits 15-12 set to Z, and bits 11-0 set to Z. Arrows point from labels 'SSI OFFSET' and 'X - Y = Z' to the bit positions in the registers.</p>
<p>Calculation Display Value</p>	<p>The diagram illustrates the calculation display value. It features a digital display showing "1.2345 INCH". Below the display are labels C1, C2, C3, C4, K1, K2. To the right is a mathematical formula: <math display="block">\left( \frac{Z}{\text{DIVIDER}} \right) \times \text{FACTOR} + \text{ADDITIVE VALUE}</math></p>

## 6.6. Dimensions

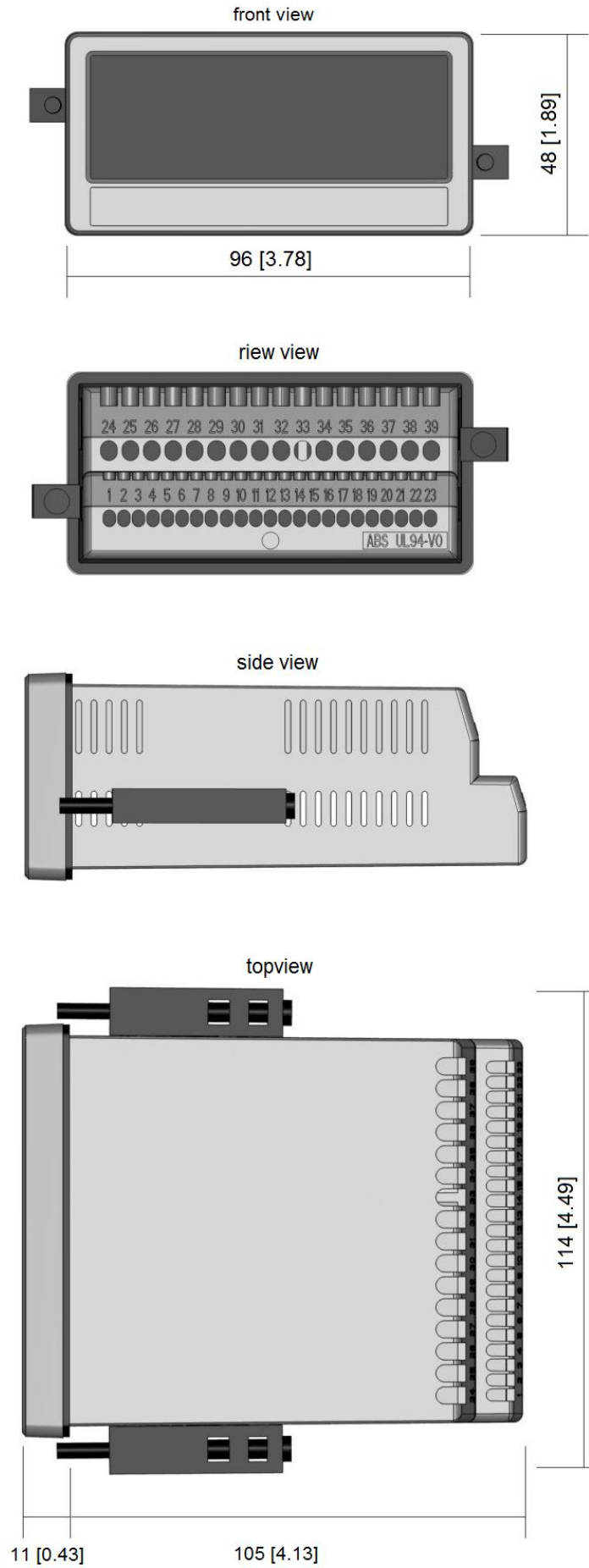



## 6.7. Technical Specifications:

Technical Specifications:		
<b>Connections:</b>	Connector type:	screw terminal, 1.5 mm <sup>2</sup> / AWG 16
<b>Power supply (DC):</b>	Input voltage:	18 ... 30 VDC
	Protection circuit:	reverse polarity protection
	Consumption:	approx. 150 mA (unloaded)
	Fuse protection:	extern: T 0.5 A
<b>Power supply (AC):</b> (Option AC)	Input voltage:	115 / 230 VAC (60/50 Hz)
	Power consumption:	approx. 5 VA (unloaded)
	Fuse protection:	extern: T 0.1 A
<b>Encoder supply:</b>	DC version:	24 VDC (approx. 1 V lower than the power supply voltage), max 250 mA
	AC version:	24 VDC (± 15%), (max 150 mA until 45°C / 80 mA by more than 45°C)
<b>Encoder supply:</b> (IX355)	DC version:	24 VDC (approx. 1 V lower than the power supply voltage), max 250 mA or 5 VDC (± 15%), max. 250 mA
	AC version:	24 VDC (± 15%) (max 150 mA until 45°C / 80 mA by more than 45°C) or 5 VDC (± 15%), max. 250 mA)
<b>SSI interface:</b>	Number (channels):	1 (Clock, /Clock, Data, /Data)
	Configuration:	Master or Slave
	Format:	Binary or Gray code
	Frequency:	Max. 1 MHz
	Resolution:	10 ... 32 Bit
	Load:	Max. 2 mA / Ri > 10 kOhm / 47 pF
<b>Control inputs:</b>	Number of inputs:	3
	Format:	HTL, PNP (10 ... 30 V)
	Frequency:	Max. 10 kHz
	Load:	Max. 2 mA / Ri > 15 kOhm / 470 pF
<b>Analog output:</b> (Option AO/AR)	Configuration:	current or voltage operation
	Voltage output:	-10...+10 V (Low 0 ... 3 V, High 9 ... 30 V)
	Current output:	0/4 ... 20 mA (burden: max. 270 Ohm)
	Resolution:	16 Bit
	Accuracy:	± 0,1 %
	Reaction time:	< 150 ms
<b>Control outputs:</b> (Option AO/AR/CO/CR)	Number of outputs:	4
	Format / level:	5 ... 30 V (depends on the Com+ voltage), PNP
	Output current:	Max. 200 mA
	Reaction time:	< 1 ms
<b>Relay outputs:</b> (Option RL)	Number of outputs:	2
	Configuration:	potential free changeovers
	AC-Switching capacity:	Max. 250 VAC / 3 A / 750 VA
	DC-Switching capacity:	Max. 150 VDC / 2 A / 50 W
	Reaction time:	< 20 ms

<b>Serial interface:</b> (Option AO/AR/CO/CR)	Format (Option AO/CO): Format (Option AR/CR) Baudrate:	RS232 RS485 9600, 19200 or 38400 baud
<b>Display:</b>	Type: Display range: Digit height Color: Operation:	LCD (backlight) 8 digits plus sign (-99999999 ... 999999999) 13 mm height red / green / yellow (switchable) resistive touchscreen
<b>Housing:</b>	Material: Mounting: Dimensions (w x h x d): Cut out (w x h): Protection class: Weight:	ABS, UL 94 V-0 panel cut out 96 x 48 x 116 mm / 3.78 x 1.89 x 4,56 inch 91 x 44 mm / 3.58 x 1.69 inch IP65 (front), IP20 (rear) approx. 200 g
<b>Ambient temperature:</b>	Operation: Storage:	-20 °C ... +60 °C resp. -4 ... 140 °F -25 °C ... +70 °C resp. -13 ... 158 °F
<b>Conformity and standards:</b>	EMC 2004/108/EC:  LV 2006/95/EC RoHS 2011/65/EU:	EN 61000-6-2, EN 61000-6-3, EN 61000-6-4 EN 61010-1 EN 50581